



IEEE REFERENCE:

ZigBee based Full Duplex Wireless communication to interchange secured data

Sun Jinsheng Wang Ning Liu Liping

Sch. of Mech. & Electr. Eng., Dalian Nat. Univ., Dalian;

This paper appears in: **Information Acquisition, 2006 IEEE International Conference on**

Publication Date: 20-23 Aug. 2006

On page(s): 473-477

Location: Shandong,

ISBN: 1-4244-0528-9

INSPEC Accession Number: 10215951

Digital Object Identifier: 10.1109/ICIA.2006.305760

Current Version Published: 2007-02-12



| | | |
|----------------------|---|--|
| Title of the project | : | Secured Full Duplex Wireless Data Transmission & Reception using Zigbee |
| Domain | : | Wireless Embedded Systems Design |
| Software | : | Embedded C, Keil, Proload |
| Microcontroller | : | AT89S52 |
| Power Supply | : | +5V, 500mA Regulated Power Supply |
| Transmitter Display | : | LED 5mm, 16 X 2 LCD |
| Receiver Display | : | LED 5mm, 16 X 2 LCD |
| Input Source | : | Key Pad |
| Crystal | : | 11.0592MHz |
| Communication Device | : | Zigbee Module |
| Applications | : | Wireless Communication |
| Developed By | : | M/S Wine Yard Technologies |
| Phone | : | 040-64 64 63 63, www.WineYardProjects.com |



Two-way Wireless Data Messaging System for Rural Areas using Zigbee Technology

In this project, the data can be transmitted to and received from remote ZigBee communication device. Data Security is primary concern for every communication system. There are many ways to provide security data that is being communicated. However, what if the security is assured irrespective of the hackers are from the noise. This Project describes a design of effective security for data communication by designing standard algorithm for encryption and decryption.

Zigbee is a PAN technology based on the IEEE 802.15.4 standard. Unlike Bluetooth or wireless USB devices, ZigBee devices have the ability to form a mesh network between nodes. Meshing is a type of daisy chaining from one device to another. This technique allows the short range of an individual node to be expanded and multiplied, covering a much larger area.

The source information is generated by a key pad and this will be encrypted and is sent to destination through Zigbee modules. The receiving system will check the data and decrypt according to a specific algorithm and displays on the LCD.

This project uses regulated 5V, 500mA power supply. 7805 three terminal voltage regulator is used for voltage regulation. Bridge type full wave rectifier is used to rectify the ac out put of secondary of 230/12V step down transformer.



Block Diagram: Transmitter – Data Encryption and Decryption

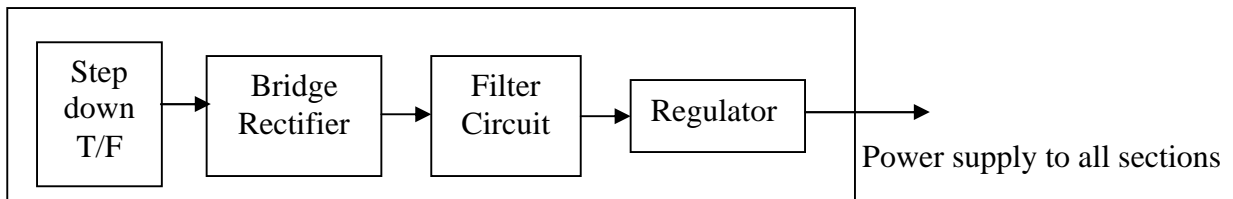
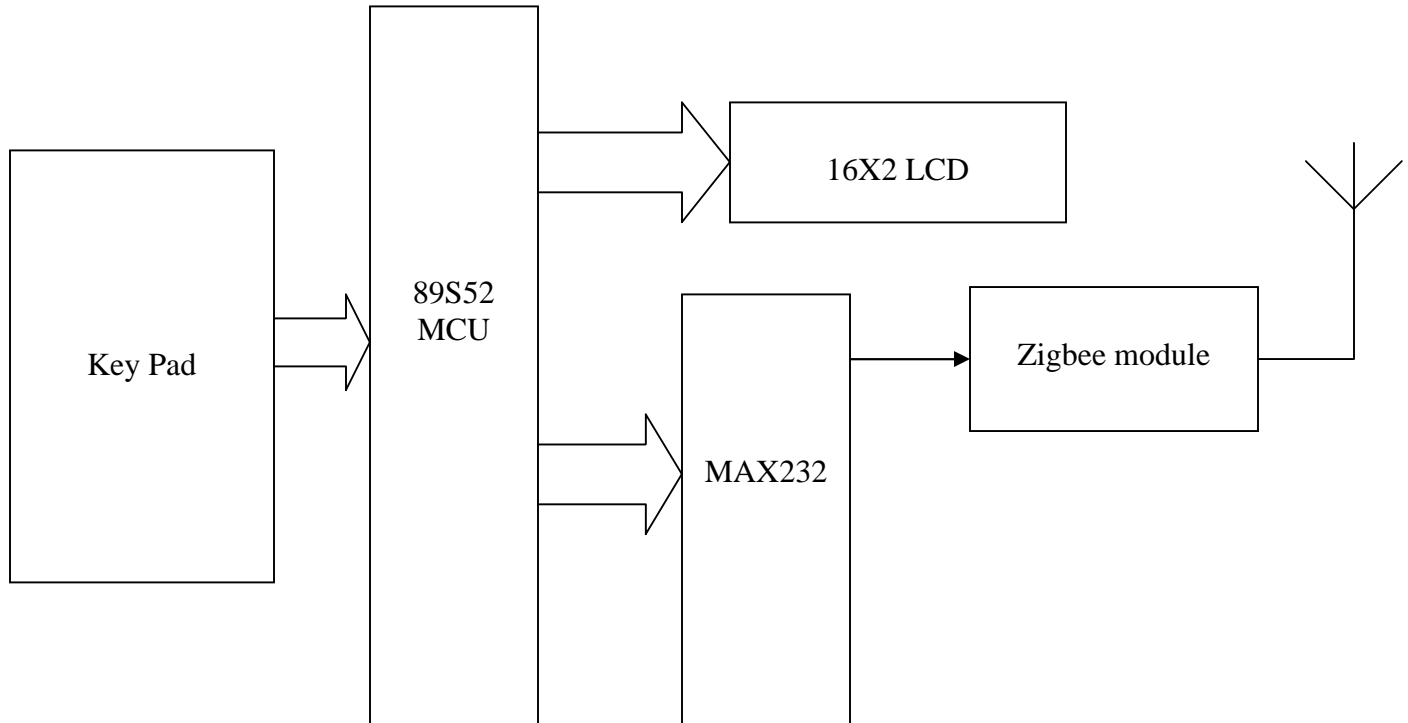

Block Diagram: Receiver – Data Encryption

